

Starter motor mounting, "NC" and "HU" models

3.0 GS

Distribution:

Date: 1-1996

Binder: C

Page: 1(1)

Important Information - Product Failure may Result!

All 3.0 GS models s/n 4110112427 - 4110129759 starter motors should be removed and inspected for cracks. This due to vibration resulting from harmonics at certain RPM. The starter bolts may break and/or the starter housing may crack (figure 1) with extended engine operation at these RPM. If cracks are found, replace starter. Install starter bracket kit 3855672-6, and insure the starter mounting bolts have washers p/n 3854496-1 installed. Torque starter mounting bolts to 40 Nm (29.5 ft.lb).

DANGER

Disconnect battery before performing any operations associated with removing the starter. Failure to do so may result in personal injury and or damaged equipment.

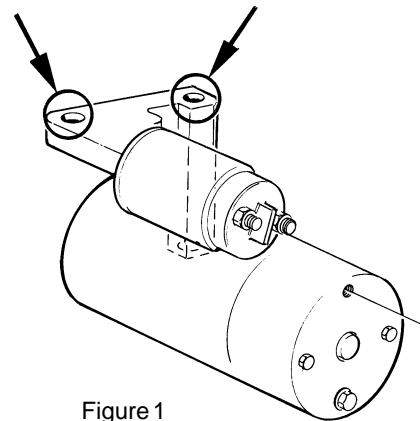

Figure 1

Starter bracket kit p/n 3855672-6 will add a bracket to the upper starter motor housing bolt. The bracket will attach the rear starter motor housing to the cylinder block as illustrated in figure 2. This will prevent premature failure to the bolts and consequent housing damage. Kits can be ordered through Volvo Penta Parts Department in the normal manner.

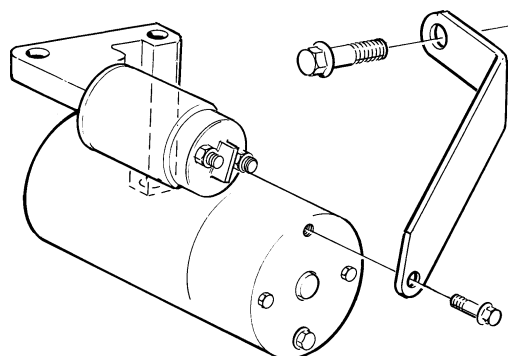

Figure 2